

OZ OPTICS LTD.

Preliminary

**APPLICATION
NOTE**

**OPTICAL
FIBER LENGTH
METER**

The information/data furnished in this document shall not be duplicated, used or disclosed in whole or in part for any purpose other than to which it was intended

INTRODUCTION

The OZ Optics Benchtop Optical Fiber Length Meter (OFLM) delivers fast, accurate and reliable measurements of optic fiber lengths. This tool saves time and money while preventing measurement errors and improving quality control. The OFLM delivers highly accurate optical light-path length measurements for distances up to 500 m. The system reports its measurements to the bench top's LCD or to a personal computer via its USB, allowing easy data logging and reporting. The OFLM is an essential tool for constructing and testing fiber optic cables, fiber optic sensors and interferometers, and other optical fiber systems where length must be controlled.

This application note is intended to provide the user with information on how to use OZ Optics' fiber length meter. It includes the theory of operation, importance of index of refraction values for OFLM measurements, and the calibration procedure for the OFLM.



APPLICATIONS

- Optical fiber cable assembly
- Production testing
- Optical network field installation
- Quality control and acceptance testing
- Fiber optic sensor assembly and testing
- Construction of fiber interferometers
- Ring laser manufacturing
- Cable management

THEORY OF OPERATION

OZ Optics' OFLM products provide customers with single port or dual port versions. The measurement principle of both options operates on the basis of comparative phase measurements of the transmitted and received signals. It uses a laser diode with a nominal 650 nm wavelength as its source. The laser diode sends out a beam to the fiber under test. In the case of a 2-port meter, a detector receives the signal at the far end of the fiber. For a 1-port meter, a portion of the light is reflected from the far end of the fiber back towards the laser source. This light is diverted to a detector. For both versions of the meter, the phase shift of the received signal varies directly with the distance travelled through the fiber. The phase shift with a 1-port OFLM will be twice the phase shift of a 2-port OFLM when measuring the same fiber, since the light travels through the fiber twice (down and back) but the firmware takes this into account.

The phase shift only depends on the speed of light in the fiber. The speed of light in the fiber is simply the product of the speed of light in a vacuum and the index of refraction (IOR) of the medium through which the light is passing (ie fiber core). Since the speed of light in a vacuum is constant, the only variable is the index of refraction.

The IOR normally varies with several parameters such as wavelength, refractive index profile, and fiber type. The user must set the correct IOR value of the fiber they are measuring.

The IOR is slightly different at different wavelengths of light because the refractive index of a medium is a function of wavelength. Also, the mode-field diameter in an optical fiber changes with wavelength. Fiber suppliers usually provide the IOR value at nominal wavelengths such as 1310 nm and 1550 nm. In our case, IOR should be set at 650 nm. If you are uncertain of the value of the IOR at this wavelength, please contact the fiber supplier to obtain the IOR value for this wavelength. The IOR of an optical fiber also varies with the refractive index profile. The refractive index profile is achieved by the fiber manufacturer by varying the level of dopants in the fiber core, and it alters the glass IOR. For multimode fiber with a graded refractive index profile, the IOR is highly influenced by the launching condition. The launch condition directly determines the location of modes that are excited within the fiber. If the modes are changing during the measurement time, it gives more uncertainties of fiber length measurements.

In order to measure the length of any assembled patchcord using a single port version of the meter, the end of the fiber under test must be flat cleaved or polished for the reflected light to be sufficient for detection. Angled endfaces will not reflect the light back along the fiber, resulting in a loss of signal. If the fiber being measured has an angled connector on the end, then a short fiber patch cord may be mated to it, with a flat, unconnected end, to reflect the light. The length of the mating fiber can then be subtracted from the total length, to give the length of the fiber under test.

For the dual port version, both ends of the fiber under test must be accessible. With the dual port version, the fiber ends connected to the meter should match the receptacles on the meter. If the fiber being tested does not have matching connectors, then short jumpers may be connected to match the ends. It is important to realize that when using loose-jacketed fiber, the length of the fiber inside the cable may actually be slightly longer than the length of the cable itself. If the fiber has only one end accessible, the dual port version can also be converted into a single port version by adding a coupler.

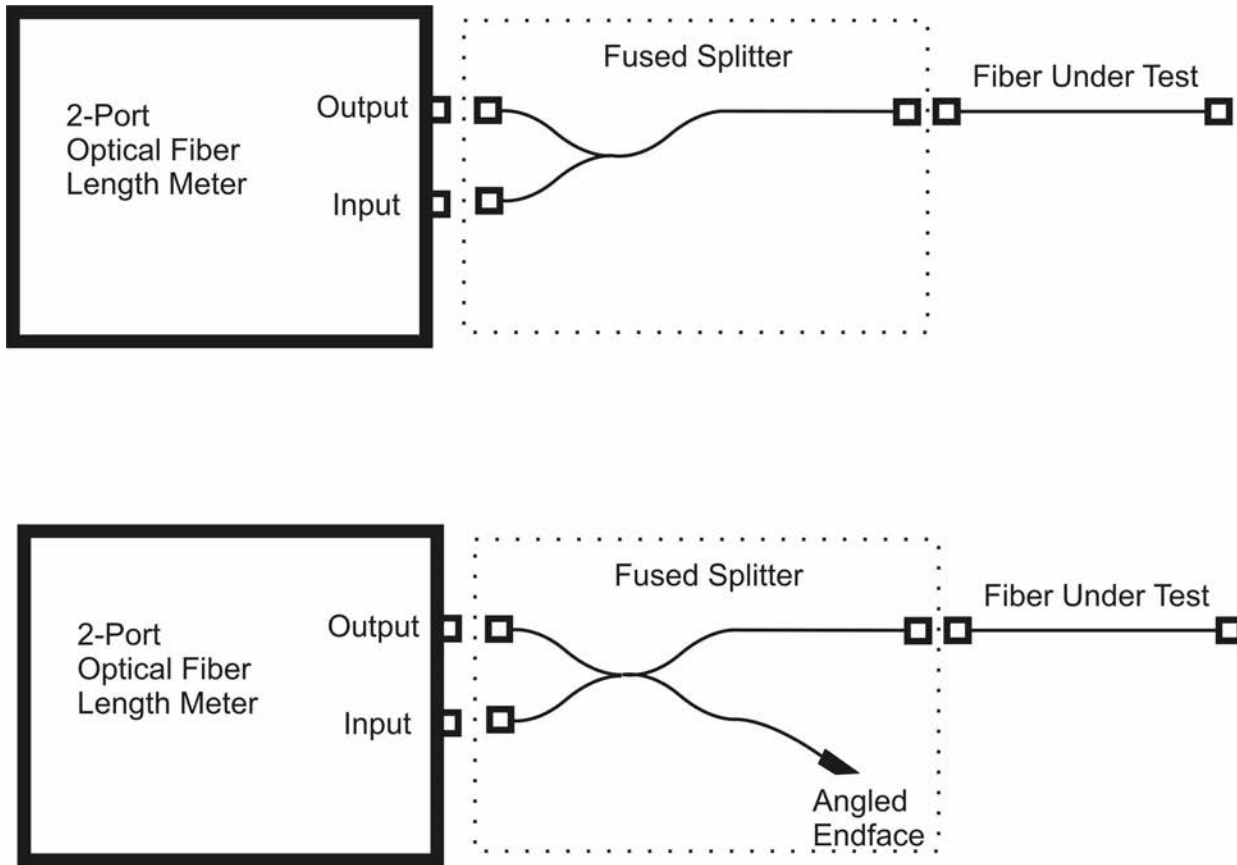

Figure 1: Converting a 2-port OFLM for single-ended measurements.

Fused splitters may come with either 3 legs or 4 legs. A splitter with 3 legs is essentially the same as a splitter with 4 legs with one of the legs cut off. If the fourth leg is present, it should be terminated with an angled endface. This ensures that light that is reflected from the endface will be directed out of the core of the fiber, thereby minimizing the amount of light reflected back to the Fiber Length Meter.

Zero the meter before attaching the Fiber Under Test. Subsequent measurements must be divided by two, in order to determine the length of the fiber, since the light will be passing through the fiber twice (down and back).

MEASUREMENT ACCURACY

It is very important that the index of refraction be accurately known at the laser wavelength, in order to make an accurate measurement of the fiber length. Any error in the IOR will result in a measurement error. In order to make accurate length measurements, the IOR for the fiber must be determined. The IOR will vary from one fiber type to another. It may also vary for comparable fibers from different manufacturers.

CALIBRATION of IOR

Calibration procedure of IOR

The process for measuring the IOR is essentially the same as the process for measuring the length of an unknown fiber. It is always helpful to average a number of measurements to reduce the measurement error.

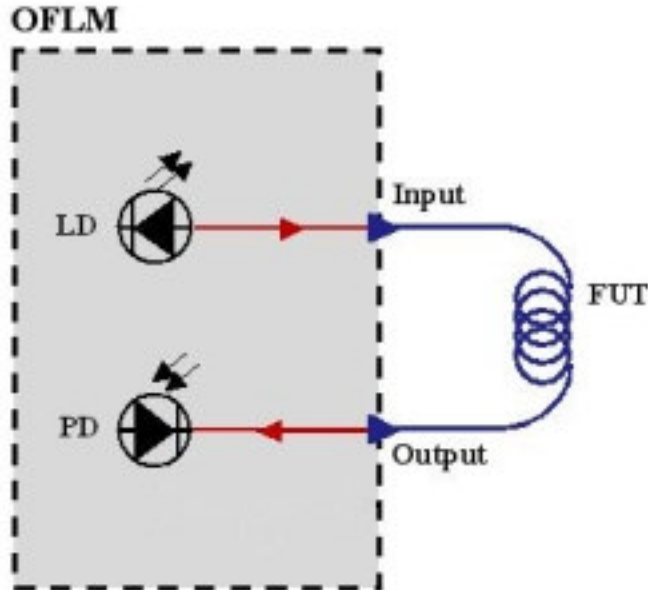

Figure 2: OFLM configuration to illustrate calibration procedure

Figure 2 illustrates the calibration setup of an OFLM. The following procedure can be used to determine the IOR for one type of the fiber under test (FUT):

1. Prepare two reference patch cords (same type of fiber) with different lengths. Typically, patch cords of about one meter and two meters in length are used, although other lengths can also be used.
2. Measure lengths of the two patch cords with a ruler, with an accuracy of 1mm. Record the lengths as L_i ($i=1,2$).

3. Set the IOR in the system, n_{set} , to 1. For calibration purposes, it must be set to 1, regardless of the actual index of refraction of the fiber. The IOR can be set by using the second page of the “Configuration” menu displayed on the LCD screen.
4. Connect each of the two patch cords to OFLM separately and record the measurement lengths reported by OFLM as L_{mi} ($i=1,2$).; Note that the measured lengths displayed on the OFLM may change if the fiber is moved. An average measurement value should be recorded to do the calibration.
5. To calculate the real IOR, the following two equations are applied, where L_0 refers to all system offsets, which are lumped together into one term.

$$L_{m1} = n * L_1 + L_0 ; \tag{1}$$

$$L_{m2} = n * L_2 + L_0 \tag{2}$$

Subtracting equation (1) from equation (2) and rearranging terms gives:

$$n = (L_{m2} - L_{m1}) / (L_2 - L_1) ; \tag{3}$$

6. Set the new calibrated IOR n into the system. The system is now ready to perform measurements. Note that the system offset value, L_0 , is already calibrated at the factory before sending to customers. The internal system offset does not affect the determination of the index of refraction of the fiber.

Calibrated IOR values

OZ Optics provides the IOR values for six commonly used fibers. The user can choose the IOR value from a drop down table according to the type of fiber under test. The first four fiber types of Table 1 shows the calibrated IOR values in our drop down table. The user can define last two fiber types according to their application. For example here we set IOR values for 50/125 um and 62.5/125 um multimode fiber.

For other types of fiber, one can calibrate the IOR by following the above procedure.

Fiber Type	Fiber Manufacturer	Calibrated IOR
SMF (5/125um)	Nufern	1.47991
SMF(6/125um)	Corning Inc Photonics Technologies Division	1.482
SMF(9/125um)	Corning SMF28e+	1.47943
PMF(8/125um)	Corning Inc Photonics Technologies Division	1.48073
MMF (50/125)	IEWC Global Solutions	1.48910
MMF(62.5/125)	Corning Inc Photonics Technologies Division	1.50380

Table 1: Calibrated IOR for different types of fiber.

OFLM measurement Accuracy

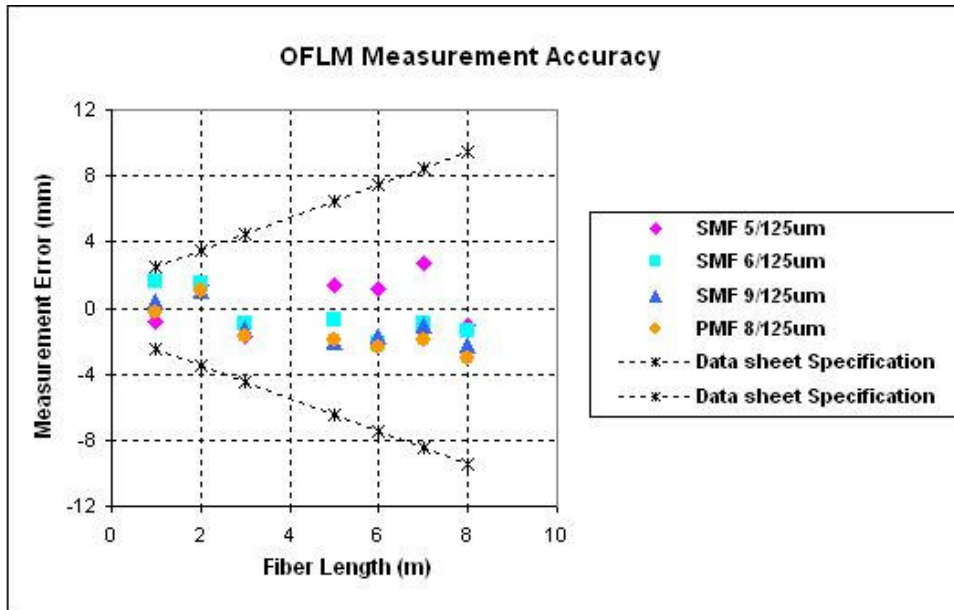

Figure 3: Measurement error for different types of fiber of different lengths.

Figure 3 shows the measurement accuracy of our OFLM with the proper calibrated IOR. The two dash lines shown in the graph indicate the measurement accuracy range defined in our specification $\pm (0.1\%L + 1.5\text{mm})$. The 4 types of fiber patch cords with length from 1m to 8 m are tested by the OFLM and the measurement errors are all within our specification.

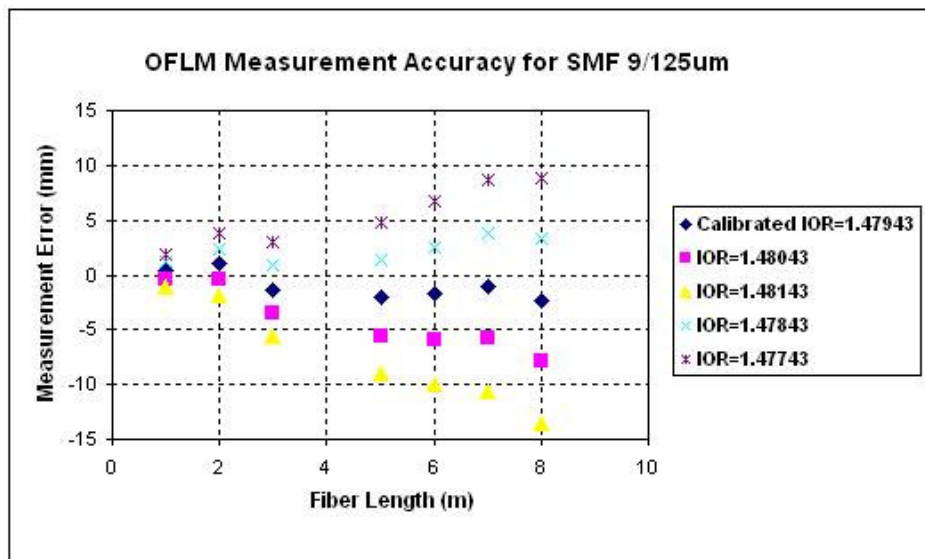

Figure 4: Measurement accuracy with the calibrated IOR and uncalibrated IOR for SMF28 .

Figure 4 compares the measurement accuracy of an OFLM with the calibrated IOR and uncalibrated IORs for single mode fiber with 9um core and 125 um cladding. It shows that with the correct calibrated IOR, measurement accuracy is enhanced especially for the longer length. Thus, proper determination of the IOR for the fiber under test is essential for measurement accuracy.

System repeatability

Since the wavelength of the laser source of our OFLM is 650 nm, it excites the higher order modes for fiber cores larger than 4 um. For the most commonly used single mode fiber, with 9um core, it actually behaves like a multimode fiber. The IOR is dependent on the launching condition in this case, which may cause changes in the measured length. Figure 4 shows 100 measurements for SMF 28, using both a single port version and a dual port version of the OFLM. The measurements vary, due to changes of modes in every measurement. The repeatability of our dual port OFLM is 6mm and it is decreased by half with the single port version. If the proper calibration is applied, the single port version enhances the measurement accuracy by a factor of 2.

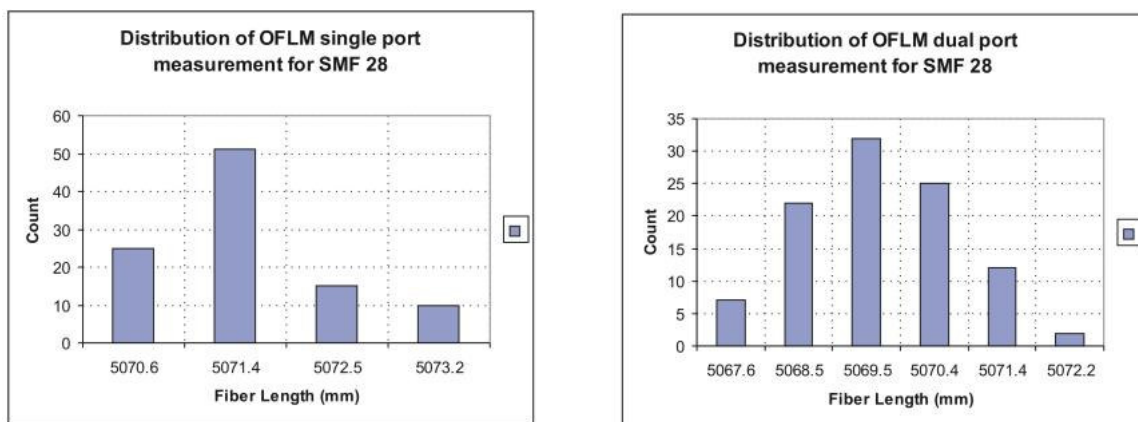

Figure 5: Measurement length distribution for SMF 28 fiber.