



OZ Optics

shop.ozoptics.com
www.ozoptics.com

219 Westbrook Road
Ottawa, ON, Canada, K0A 1L0

Toll free: 1-800-361-5415
Telephone: 1-613-831-0981
Fax: 1-613-836-5089
sales@ozoptics.com

ALL FIBER POLARIZATION CONTROLLER

Features

- No intrinsic loss
- No backreflection
- Compact size
- Easy to use
- Wavelength insensitive
- Low cost
- 400–2200 nm wavelength range

Applications

- Singlemode to Polarization Maintaining (PM) fiber launching
- Polarization Dependent Loss (PDL) measurements
- Launching into Polarization sensitive devices
- Fiber lasers
- Fiber interferometers
- OCT systems

Product Description

Polarization controllers allow one to convert any input polarization to any desired output polarization. The device combines the compact size and ease of use of standard bulk optics systems with low costs, low losses, and low backreflections.

The controller works by applying pressure with an adjustable clamp. The pressure on the fiber causes a birefringence within the fiber core, causing the fiber to act as a fractional wave plate. Varying the pressure varies the delay between the fast and slow polarization components. The clamp is rotatable, allowing one to change the direction in which the stress is applied. This allows any output polarization to be achieved. The process is simple and quick. Output polarizations exceeding 30 dB can be routinely achieved in seconds.

The fiber polarization controller works with singlemode fiber of any wavelength. The controller does not work with multimode or Polarization Maintaining (PM) fiber. For multimode and PM fiber OZ Optics still offers their standard series of polarization rotators and analyzers (refer to the Polarization Rotators / Controllers / Analyzers data sheet).

All fiber polarization controllers are offered in three versions. The in-line polarization controller can be inserted onto a customer's own singlemode fiber. We now offer this unit in a miniature size housing, for applications where space is critical. It can be used with any wavelength singlemode fiber. The in-line version is designed to work with only 250 micron and 400 micron jacketed fibers. Secondly, a pigtailed version is also offered. This version is available with any size of cable or fiber, and with your choice of connectors. Finally, a connector receptacle style controller is available, using a short section of fiber terminated with female receptacles. For further information contact OZ Optics.

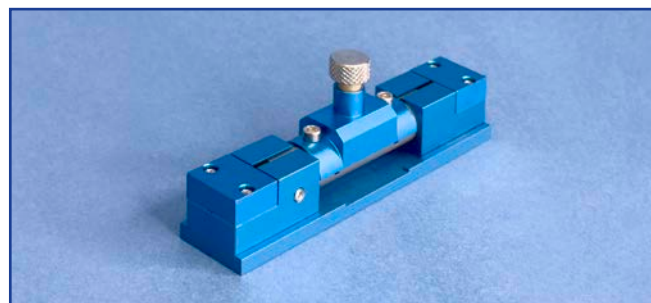

Miniature In-Line Polarization Controller Without Fiber

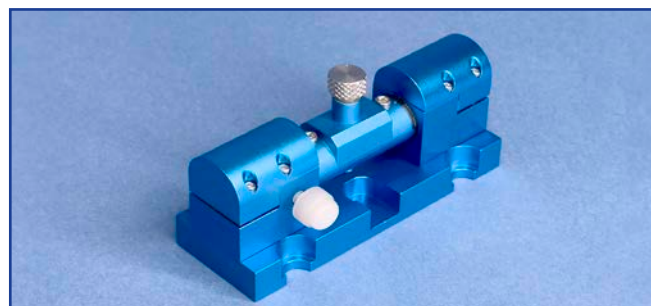

Standard Size In-Line Polarization Controller Without Fiber

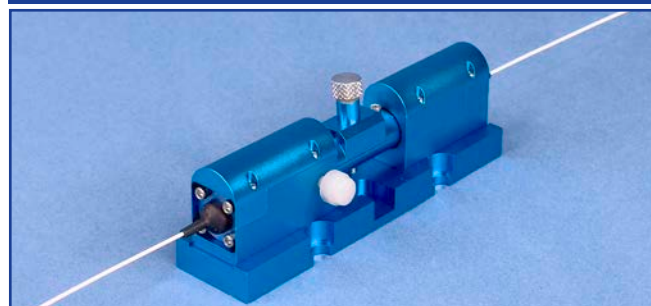

In-Line Polarization Controller With Fiber

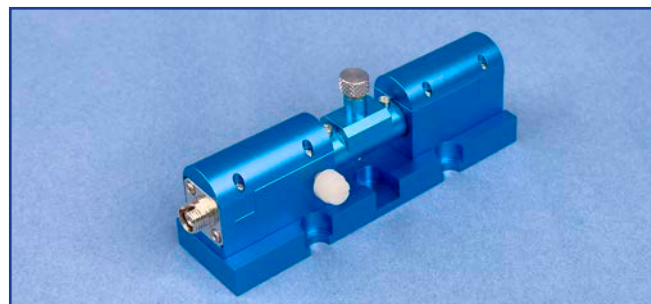

Receptacle Style Polarization Controller

Standard Product Specifications

Parameter	Condition	Units	Value
Return loss (intrinsic)		dB	Limited only by the return loss of the input and output connections
Return losses of connections ¹	Super PC finish	dB	40
	Ultra PC finish	dB	50
	Angled PC finish	dB	60
Insertion loss ¹		dB	Intrinsic loss limited by fiber only, Connector losses <0.5 dB ¹
Polarization extinction ratio		dB	>35 achievable
Maximum fiber coating size		microns	up to 400 um for FPC style
Wavelength range		nm	400–2200 (depending on fiber used) ²
Size		inches	See Figures 1-4

¹ For telecommunication wavelengths only, and for pigtailed versions only (PFPC and HFPC)

² See Table 1 of the *Standard Tables* http://www.ozoptics.com/ALLNEW_PDF/DTS0079.pdf for standard singlemode fibers. For standard products please see our online catalog <http://shop.ozoptics.com>

Ordering Information for Standard Parts

The following items are all standard. Connectors can be added to fibers as per customer specifications.

In-Line Polarization Controller Without Fiber		
Bar Code	Part Number	Description
2575	FPC-100	All Fiber Polarization Controller for customer installed 250 or 400 micron diameter coated fiber
30480	FPC-200	All Fiber Polarization Controller, miniature size, for customer installed 250 or 400 micron diameter coated fiber

Receptacle Style Polarization Controllers		
Bar Code	Part Number	Description
13133	HFPC-11-800-S-5/125-3S3S	All Fiber Polarization Controller for 800 nm with 5/125 singlemode fiber and Super FC/PC receptacles on both ends.
16607	HFPC-11-980-S-6/125-3S3S	All Fiber Polarization Controller for 980 nm with 5/125 singlemode fiber and Super FC/PC receptacles on both ends.
6311	HFPC-11-1300/1550-S-9/125-3S3S	All Fiber Polarization Controller for 1300/1550 nm with 9/125 singlemode fiber and Super FC/PC receptacles on both ends.
11268	HFPC-11-1300/1550-S-9/125-3U3U	All Fiber Polarization Controller for 1300/1550 nm with 9/125 singlemode fiber and Ultra FC/PC receptacles on both ends.
6324	HFPC-11-1300/1550-S-9/125-3A3A	All Fiber Polarization Controller for 1300/1550 nm with 9/125 singlemode fiber and FC/APC receptacles on both ends.

Pigtailed Polarization Controllers With Fiber, 0.9 mm OD Cable		
Bar Code	Part Number	Description
23207	PFPC-11-400-S-3/125-XX-1-1	All Fiber Polarization Controller with 1 meter long 900 micron OD jacketed 400 nm 3/125 singlemode fiber pigtails with no connectors.
23208	PFPC-11-488-S-3.5/125-XX-1-1	All Fiber Polarization Controller with 1 meter long 900 micron OD jacketed 488 nm 3.5/125 singlemode fiber pigtails with no connectors.
23209	PFPC-11-633-S-4/125-XX-1-1	All Fiber Polarization Controller with 1 meter long 900 micron OD jacketed 633 nm 4/125 singlemode fiber pigtails with no connectors.
23210	PFPC-11-800-S-5/125-XX-1-1	All Fiber Polarization Controller with 1 meter long 900 micron OD jacketed 800 nm 5/125 singlemode fiber pigtails with no connectors.
23211	PFPC-11-980-S-6/125-XX-1-1	All Fiber Polarization Controller with 1 meter long 900 micron OD jacketed 980 nm 6/125 singlemode fiber pigtails with no connectors.
18923	PFPC-11-1300/1550-S-9/125-XX-1-1	All Fiber Polarization Controller with 1 meter long 900 micron OD jacketed 1300/1550 nm 9/125 singlemode fiber pigtails with no connectors.

Pigtailed Polarization Controllers With Fiber, 3 mm OD Cable		
Bar Code	Part Number	Description
23214	PFPC-11-400-S-3/125-XX-3-1	All Fiber Polarization Controller with 1 meter long 3 mm OD Kevlar reinforced PVC cable 400 nm 3/125 singlemode fiber pigtails with no connectors.
23215	PFPC-11-488-S-3.5/125-XX-3-1	All Fiber Polarization Controller with 1 meter long 3 mm OD Kevlar reinforced PVC cable 488 nm 3.5/125 singlemode fiber pigtails with no connectors.
23216	PFPC-11-633-S-4/125-XX-3-1	All Fiber Polarization Controller with 1 meter long 3mm OD Kevlar reinforced PVC cable 633 nm 4/125 singlemode fiber pigtails with no connectors.
17819	PFPC-11-800-S-5/125-XX-3-1	All Fiber Polarization Controller with 1 meter long 3 mm OD Kevlar reinforced PVC cable 800 nm 5/125 singlemode fiber pigtails with no connectors.
23217	PFPC-11-980-S-6/125-XX-3-1	All Fiber Polarization Controller with 1 meter long 3 mm OD Kevlar reinforced PVC cable 980 nm 6/125 singlemode fiber pigtails with no connectors.
20513	PFPC-11-1300/1550-S-9/125-XX-3-1	All Fiber Polarization Controller with 1 meter long 3 mm OD Kevlar reinforced PVC cable 1300/1550 nm 9/125 singlemode fiber pigtails with no connectors.

Ordering Example For Standard Parts

A university scientist is building a fiber interferometer and needs to manipulate the polarization of the light travelling through the fiber. He is using standard singlemode fiber for telecommunication wavelengths, and is using a 1480 nm source. To minimize reflections in his system he is using FC connectors with an APC finish. Based on this, a receptacle style controller will work in his application.

Bar Code	Part Number	Description
6324	HFPC-11-1300/1500-S-9/125-3A3A	All Fiber Polarization Controller for 1300/1500 nm with 9/125 singlemode fiber and FC/APC receptacles on both ends.

Questionnaire

- Which of the following options best describes your needs?
 - I want to install and remove my own fiber.
 - I want a specific fiber permanently installed.
 - I want receptacles on either side to plug devices into.
- What wavelengths are you using?
- For pigtail style models, what should be the fiber length and cable type?
- For both pigtail and receptacle styles, what type of connector are you using?
- What is the intensity of the light travelling through the fiber?

Ordering Information For Custom Parts

Pigtail Version:

PFPC-11-W-S-a/b-XY-JD-L

Wavelength: Specify in nanometers
(Example: 1550 for 1550 nm)

Fiber core/cladding sizes, in microns
9/125 for 1300/1550 nm SM fiber.
See Table 1 of the *Standard Tables*
http://www.ozoptics.com/ALLNEW_PDF/DTS0079.pdf
for other standard fiber sizes

Fiber length, in meters, on each side of the device
If the input and output lengths are different, specify both lengths, separated by a comma. Otherwise, specify a single value.

Example: To order 1 meter of fiber at the input and 7 meters at the output, replace L with 1,7

Fiber jacket type: 1 = 900 micron OD hytrel jacket
3 = 3 mm OD Kevlar reinforced PVC cable

See Table 7 of the *Standard Tables*
http://www.ozoptics.com/ALLNEW_PDF/DTS0079.pdf
for other jacket sizes

Connector Code: 3S = Super NTT-FC/PC
3U = Ultra NTT-FC/PC
3A = Angled NTT-FC/PC
8 = AT&T-ST
SC = SC
SCA = Angled SC

See Table 6 of the *Standard Tables*
http://www.ozoptics.com/ALLNEW_PDF/DTS0079.pdf
for other connectors

Receptacle Version:

HFPC-11-W-S-a/b-XY

Wavelength: Specify in nanometers
(Example: 1550 for 1550 nm)

Fiber core/cladding sizes, in microns
9/125 for 1300/1550 nm SM fiber.
See Table 1 of the *Standard Tables*
http://www.ozoptics.com/ALLNEW_PDF/DTS0079.pdf
for other standard fiber sizes

Connector Code: 3S = Super NTT-FC/PC
3U = Ultra FC NTT-FC/PC
3A = Angled NTT-FC/PC
8 = AT&T-ST
SC = SC
SCA = Angled SC

See Table 6 of the *Standard Tables*
http://www.ozoptics.com/ALLNEW_PDF/DTS0079.pdf
for other connectors

Ordering Example For Custom Parts

A fiber laser manufacturer wants to put a polarization controller in his system. His laser will operate at 1053 nm, so he needs singlemode fiber for that wavelength. He needs 10 meters of fiber installed in the device, five meters per side. For strength and safety, he is using 3 mm OD cabling. He wants FC/APC connectors on both ends.

Part Number	Description
PFPC-11-980-S-6/125-3A3A-3-5	All Fiber Polarization Controller with 5 meter long 3 mm OD Kevlar reinforced PVC cabled 980 nm 6/125 singlemode fiber pigtails with FC/APC connectors on both ends.

Application Notes

How to align to polarization sensitive devices – Install the polarization controller between your source and the device under test. Manipulate the controller until you get maximum throughput. If it is a high traffic area, it is useful to tape down or cover the single mode fiber to stabilize the polarization. If the fiber is moved, the polarization will change and you will have to realign the controller.

How to do PDL measurements – Follow the same procedure as for aligning to a polarization sensitive device (above). Record the power reading. Now adjust the controller for the minimum signal you can get. By converting these two levels to dB and taking the difference, you will have your Polarization Dependent Loss value in dB.

Frequently Asked Questions (FAQs)

Q: Why won't my fiber fit into the FPC-100?

A: The standard FPC-100 is designed to fit 250 micron or 400 micron diameter coated fiber. If 900 micron tight buffer fiber is used, please let us know when ordering. Loose tube cabled fiber is not recommended because the fiber can stay fixed as the jacketing is twisted, reducing the effectiveness of the controller.

Q: Why doesn't anything changes when I adjust the controller?

- A:** Your device may
1. Have very low polarization dependent loss (PDL)
[So no effect would be noticed] **OR**
 2. The fiber may be slipping (check clamps)
[So no change is being made] **OR**
 3. Your input light may be unpolarized
[So no effective change can be observed]

For 1 – The device you are testing is insensitive to polarization, you may see some changes using a more sensitive detector.

For 2 – Be sure you are not using loose tube jacketed cable. Tighten the clamps and retry.

For 3 – You may want to use a polarized source (such as the OZ Optics Polarized Fiber Optic Source) to supply light with a stable polarization state that you can manipulate.

Q: Why is the power/polarization through my device fluctuating?

A: Check if the input polarization is fluctuating, make sure the fiber is immobile and that the temperature is stable. If there is a large reflection coming from another component in your system, it may be causing the problem, and you may need to install an isolator (see the *Fiber Optic Isolators* data sheet) to defeat these reflections and stabilize your source.

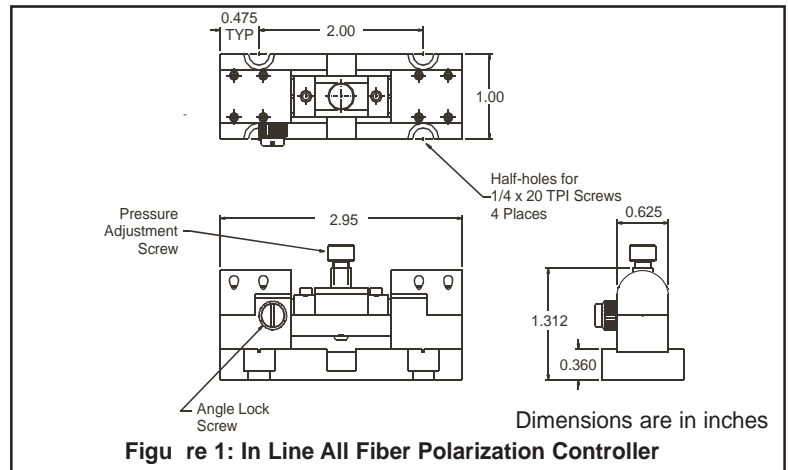

Figure 1: In Line All Fiber Polarization Controller

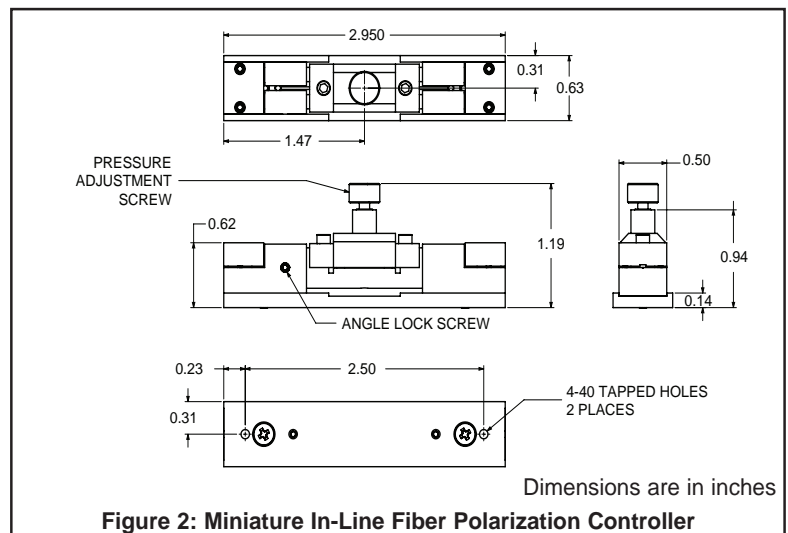

Figure 2: Miniature In-Line Fiber Polarization Controller

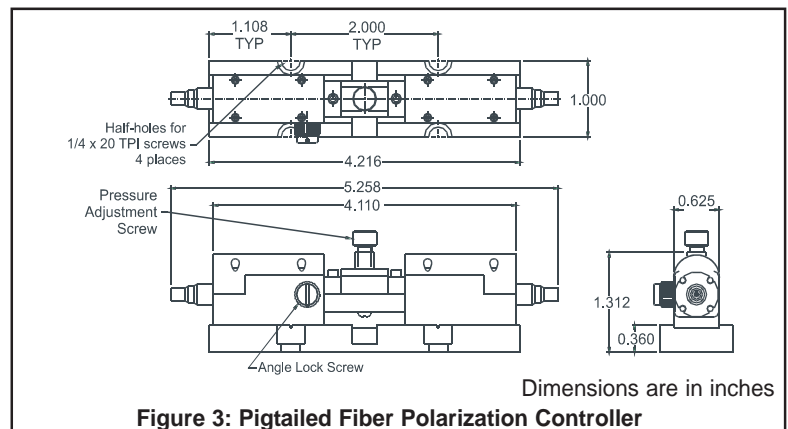

Figure 3: Pigtailed Fiber Polarization Controller

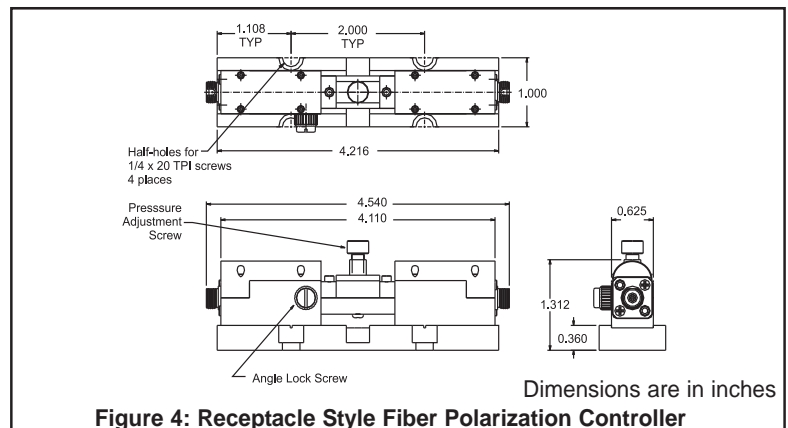

Figure 4: Receptacle Style Fiber Polarization Controller