



OZ Optics

shop.ozoptics.com
www.ozoptics.com

219 Westbrook Road
Ottawa, ON, Canada, K0A 1L0

Toll-free: 1-800-361-5415
Telephone: 1-613-831-0981
Fax: 1-613-836-5089
sales@ozoptics.com

BACKREFLECTION METER

Features:

- Sensitivity to -70 dB
- Built-in USB communications port
- Wide range of available wavelengths
- Built-in source
- Dual wavelength source available
- Rugged and compact design
- High resolution
- Optional insertion loss measurement capability

Applications:

- Backreflection measurement of components
- Insertion loss measurement
- End-to-end loss measurement
- Quality control
- New Product development
- Component or system troubleshooting
- Network installation



Fiber Optic Backreflection Meter

Product Description:

The OZ Optics Limited BM-100 and BM-200 Backreflection Meters measure the total accumulated optical return loss that is reflected back through a device or fiber under test. The measured reflections are caused by Rayleigh scattering, sudden changes in the refractive index within the device under test (DUT), or from connector ends.

The Backreflection Meter is configured with an FC/APC connector on the output port, to minimize unwanted reflections. The meter has either one or two built-in laser diodes for return loss measurement at specific wavelengths. An optional detector can be added to the unit for insertion loss measurements. Reference patchcords for calibration are available. Adaptor patchcords are also available, to allow the meter to be used with devices having different connectors.

The BM-100 and BM-200 Backreflection Meters can be operated remotely via the built-in USB interface. A universal AC/DC power supply is included with all units.

Ordering Information For Standard Parts:

BC	Part Number	Description
14715	BM-100-3A-1310-9/125-S	Singlemode Fiber Optic Backreflection Meter, with 1310 nm built-in source.
14727	BM-100-3A-1310-9/125-S-IL	Singlemode Fiber Optic Backreflection Meter, with 1310 nm built-in source and insertion loss measurement capability.
9853	BM-100-3A-1550-9/125-S	Singlemode Fiber Optic Backreflection Meter, with 1550 nm built-in source.
14728	BM-100-3A-1550-9/125-S-IL	Singlemode Fiber Optic Backreflection Meter, with 1550 nm built-in source and insertion loss measurement capability.
14714	BM-200-3A-1310/1550-9/125-S	Singlemode Fiber Optic Backreflection Meter, with dual 1310 and 1550 nm built-in sources.
14726	BM-200-3A-1310/1550-9/125-S-IL	Singlemode Fiber Optic Backreflection Meter, with dual 1310 and 1550 nm built-in sources and insertion loss measurement capability.
10229	SMJ-3A1-1300/1550-9/125-3-1	Reference patchcord, FC/APC to flat-polished ferrule, 9/125 micron singlemode 1300/1550 nm fiber, 3 mm OD PVC jacket, 1 m long.
8131	SMJ-3A3U-1300/1550-9/125-3-2	Adaptor patchcord, FC/APC to FC/UPC, 9/125 micron singlemode 1300/1550 nm fiber, 3 mm OD PVC jacket, 2 m long.
4267	MAND-01	Mandrel for Backreflection Meter.

Standard Product Specifications¹:

Parameter	Specification			
	BM-100-3A-1310-9/125-S	BM-100-3A-1550-9/125-S	BM-200-3A-1310/1550-9/125-S	BM-200-3A-1310/1550-9/125-S-IL
Part number				
Bar code number	14715	9853	14714	14726
Central wavelength ²	1310 ± 20 nm	1550 ± 20 nm	1310 ± 20 nm 1550 ± 20 nm	
Laser type	Fabry-Perot laser			
Output power	≥ -3 dBm			
Connector type	8° angled NTT-FC/APC receptacle			
Fiber type	9/125 micron core/cladding, singlemode fiber, Corning SMF-28			
Reflectance dynamic range	-1 to -70 dB			
Reflectance accuracy	± 0.5 dB, up to -50 dB ± 1.0 dB, up to -65 dB ± 2.5 dB, up to -70 dB			
IL detector type	N/A			3 mm InGaAs
IL dynamic range	N/A			0 to 60 dB
IL accuracy	N/A			± 0.025 dB
Long term stability ³	±0.05 dB			
Short term stability ⁴	±0.025 dB			
Input voltage	Universal 110/220 VAC to VDC adaptor			
Dimensions (L x W x D)	190 x 90 x 60 mm			
Weight	500 g			
Operating temperature	-10 to 55°C			
Storage temperature	-30 to 70°C			
Relative humidity	< 85%, RH non-condensing			

¹ Reference condition: 23°C ambient temperature after 15 minutes warm-up period

² Depends on laser diode manufacturer and operating temperature.

³ 6 hours at constant temperature and after 15 minutes warm-up period

⁴ 15 minutes at constant temperature and after 15 minutes warm-up period

Ordering Examples For Standard Parts:

A European fiber optic manufacturer must measure the backreflection and the insertion loss of singlemode and polarization-maintaining jumpers, at 1550 nm and at 1310 nm. The manufacturer needs to order the following parts:

Bar Code	Part Number	Description
14726	BM-200-3A-1310/1550-9/125-S-IL	Singlemode Fiber Optic Backreflection Meter, with dual 1310 and 1550 nm built-in sources and insertion loss measurement capability.
10229	SMJ-3A1-1300/1550-9/125-3-1	Reference patchcord, FC/APC to flat-polished ferrule, 9/125 micron singlemode 1300/1550 nm fiber, 3 mm OD PVC jacket, 1 m long.
8131	SMJ-3A3U-1300/1550-9/125-3-2	Hybrid patchcord, FC/APC to FC/UPC, 9/125 micron singlemode 1300/1550 nm fiber, 3 mm OD PVC jacket, 2 m long.

Ordering Information For Custom Parts:

Although we strongly recommend the purchase of our standard products, OZ Optics also welcomes the opportunity to provide custom-designed products to meet your application requirements. There can be a difference in the pricing for a custom-designed device or part compared to our standard parts list. Please consider the following points when reviewing your quotation:

- Additional time is required to prepare a comprehensive quotation.
- Lead times are usually longer than normal.
- Non-recurring engineering (NRE) charges and lot charges may apply.

These points will be carefully explained in your quotation, so you can make a well-informed decision.

Questionnaire For Custom Parts:

1. What is your application?
2. What wavelengths do you plan to use?
3. What connector receptacle type do you need?
4. What fiber type are you using?
5. What is the minimum backreflection you want to measure?
6. Do you want to measure insertion losses?
7. Do you want a single wavelength or dual wavelength source?

Backreflection Meter:

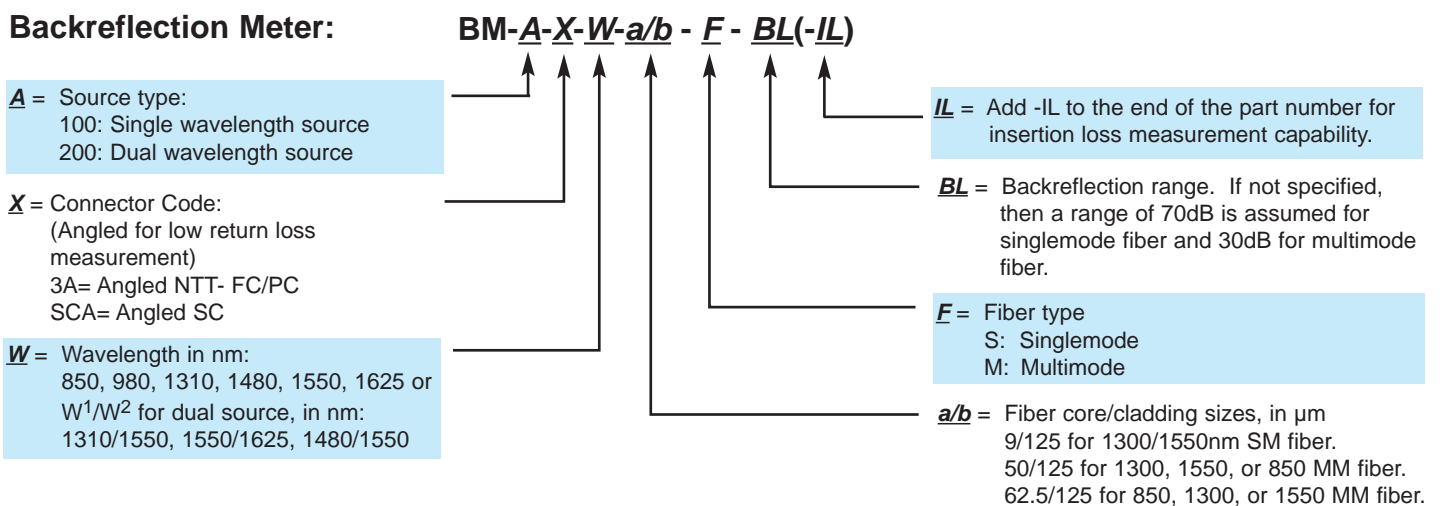

Notes:

1. For the multimode backreflection meter, the minimum measureable backreflection is -30 dB. Multimode backreflection meters are configured with LED sources.
2. For singlemode backreflection meters, the minimum measureable backreflection measurement is -70 dB, with angled FC/APC connectors, at wavelengths of 1310 nm, or higher.

Ordering Example For Custom Parts:

A North American fiber optic manufacturer must measure the backreflection of multimode fiber patchcords at 850 nm. The fiber has 62.5/125 μm core/cladding, and is terminated with an FC/PC connector. The manufacturer needs to order the following parts:

Bar Code	Part Number	Description
NA	BM-100-3-850-62.5/125-M	Multimode Fiber Optic Backreflection Meter, 62.5/125 micron, with a built-in LED at 850 nm, with FC/PC connector.
NA	MMJ-33-IRVIS-62.5/125-3-2	Multimode patchcord, FC/PC to FC/PC, 62.5/125 micron multimode IRVIS fiber, 3 mm OD PVC jacket, 2 m long.

Frequently Asked Questions (FAQs):

- Q:** What are the reference jumper and mandrel for?
- A:** The reference jumper is terminated on one end with a flat polish ferrule to produce a precise level of reflection (4% from the air/glass interface). This is used to calibrate the optical return loss measurement. The mandrel is used to attenuate the light through the fiber in order to measure and subtract out any background signals from the instrument.
- Q:** Can I measure insertion loss and return loss simultaneously, or do I have to measure them separately?
- A:** To measure return losses you have to attenuate reflections after the device under test using either the mandrel or with index matching gel. This prevents you from measuring simultaneously both IL and ORL.
- Q:** Can I measure the return losses of connectors other than FC type?
- A:** Yes. You just need to use a patchcord with an FC/APC connector on one end and with the same connector type as the new device under test on the other end. The patchcord can then be attached to the test device with a simple sleeve thru connector.
- Q:** I can't get a low enough return loss reading. What's wrong?
- A:** First make sure the receptacle and connectors are clean. Next make sure you attenuate the output light from the test device using the mandrel. If the value is still high, recalibrate the unit (Zeroing and referencing the meter) and if the measurement is still unchanged it may be due to a damaged connector. Remember that the measured return loss includes the connector return loss.
- Q:** How often should I check my meter's calibration?
- A:** When measuring low return losses (>55dB), we advise that you zero the meter before each reading. Otherwise a daily or weekly reference calibration can be performed based on meter usage.