



## BEAM SPLITTERS/COMBINERS

### Features

- High power handling
- High extinction ratio
- Highly modular and flexible design
- Wide wavelength range
- Bi-directional
- Broadband performance
- Custom designs welcomed
- Mode independent behavior in multimode fiber applications.

### Applications

- EDFA amplifier
- Raman amplifier combiner
- Polarization mode dispersion compensation
- Polarization extinction ratio measurements
- Fiber optic sensors
- Coherent communication systems and quantum cryptography
- Return loss measurement

### Product Description

Fiber optic beam splitters are used to divide light from one fiber into two or more fibers. Light from an input fiber is first collimated, then sent through a beam splitting optic to divide it into two. The resultant output beams are then focused back into the output fibers. Both 1XN and 2XN splitters can be constructed in this fashion with as many as eight or more outputs, with both low return losses and low insertion losses. This design is extremely flexible, allowing one to use different fiber types on different ports, and different beam splitter optics inside. Custom designs combining circulators, polarizing splitters and non-polarizing splitters in the same package are routinely manufactured. Splitters can be made with either fibers permanently attached to each port (pigtail style) or with receptacles on each port that one can plug your fiber into (receptacle style). We can also build source to fiber couplers with built-in beamsplitters for either laser or laser diode sources. Contact OZ for details.

Please note that we **strongly** recommend using pigtail style devices whenever possible. Mechanical tolerances on connectors and receptacles mean receptacle style devices suffer from higher losses and poorer polarization extinction ratios than pigtail style devices. This is especially true for singlemode and polarization maintaining fiber devices.

If size is a concern, we recommend that you consider our miniature line of splitters. Please refer to our data sheet titled [Miniature Inline Polarization Maintaining Splitters/Taps/Combiners](#).

The two most common types of splitters offered are polarizing beam splitters and polarization maintaining beam splitters. Their operating principles are as follows:

**Polarization Maintaining Splitters:** These splitters use a partially reflecting mirror to transmit a portion of the light from the input fiber to the main output fiber, and reflect the remainder of the light to the second output fiber. All ports made using polarization maintaining fiber are aligned so that polarized light aligned parallel to the stress rods on the input fiber emerges from the output fibers in the



Pigtail Style One-by-two Splitter

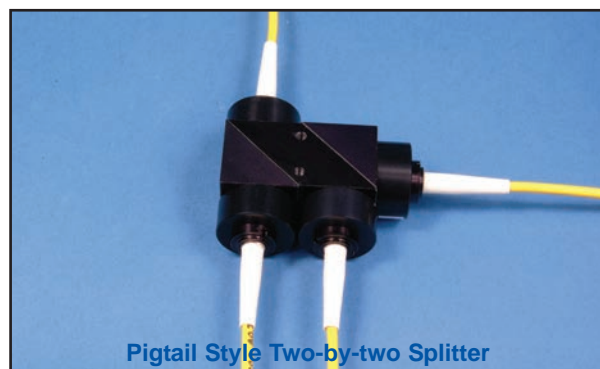

Pigtail Style Two-by-two Splitter

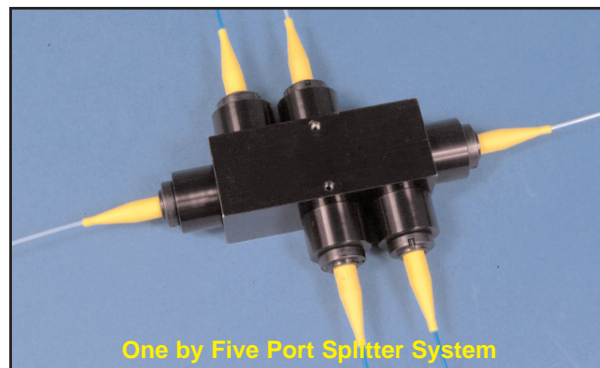

One by Five Port Splitter System



Circulator

same manner, maintaining the polarization state to a high degree.

Polarization maintaining splitters use a multi-layer coating to split the light by a specific ratio regardless of the incoming polarization. Because of the nature of these coatings, their behavior will vary somewhat with respect to wavelength, and so are recommended for an operating wavelength range of about  $\pm 10\text{nm}$ . Broadband beam splitters are offered, but with greater variation in the split ratio with respect to input polarization.

Splitters that only split off a small portion of the input light are commonly known as taps. These splitters are often used for power monitoring applications. The small signal, typically between one and ten percent, is sent to a monitoring photodiode, while the majority of the signal goes on to the main destination. For a very low cost alternative configuration, combining the functions of a tap and monitor photodiode in a single unit, we invite you to review our [Inline Optical Taps and Monitors](#) data sheet.

**Polarizing Splitters:** Polarizing Beam Splitters split incoming light into two orthogonal states. They can also be used to combine the light from two fibers into a single output fiber. When used as a beam combiner, each input signal will transmit along a different output polarization axis. It is important when using these splitters with polarization maintaining fiber that one understands how the polarization axes are aligned on each port. Figure 1 one shows the standard configuration. With this configuration, the following behavior will be observed:

- 1) Light launched along the slow axis of input port T will be transmitted along the slow axis of output port 1
- 2) Light launched along the fast axis of input port T will be transmitted along the slow axis of output port 2
- 3) Light launched along the slow axis of input port R will be transmitted along the fast axis of output port 1
- 4) Light launched along the fast axis of input port R will be transmitted along the fast axis of output port 2

This configuration can be changed based on a customer's requirements.

Please note that with polarizing splitters there are two considerations: The ability of the splitter to prevent polarized light intended for port 1 from reaching port 2 or vice versa (polarization crosstalk), and the output polarization extinction ratio of the light emerging from polarization maintaining fibers attached to each port. The crosstalk level will always be equal to or greater than the polarization extinction ratio. For example, a splitter can be produced with a high cross talk ratio, but if the output fibers have mediocre performance, then the output polarization extinction ratio would be low. Please be sure to specify both of these values if your system has special requirements.

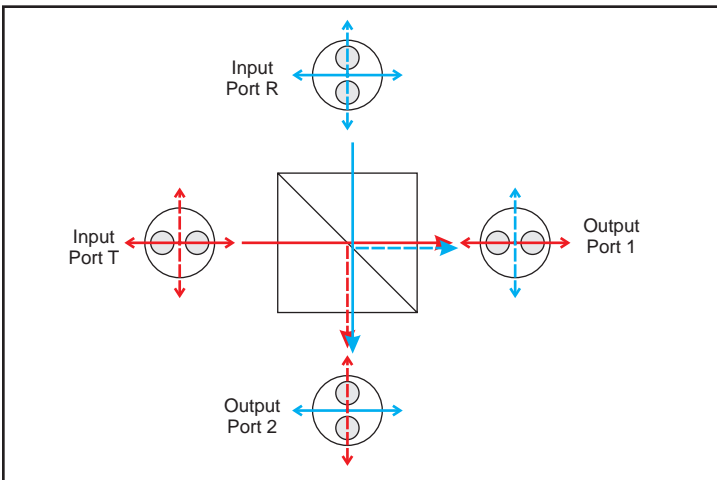
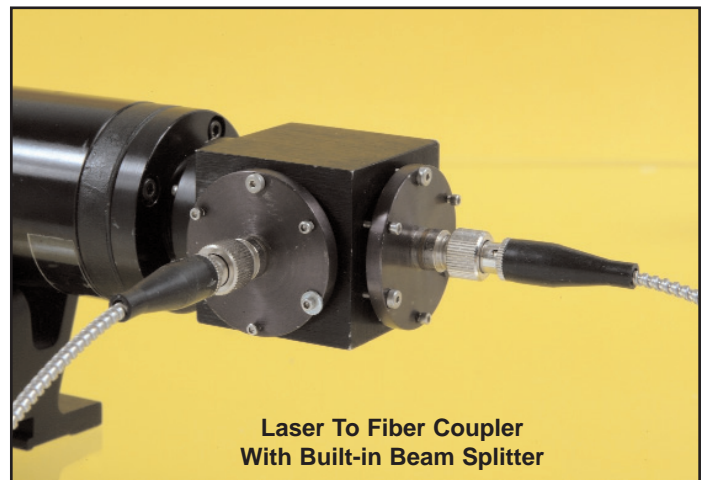

Figure 1: Standard orientation of polarization maintaining fibers on polarizing beamsplitters



Laser To Fiber Coupler With Built-in Beam Splitter

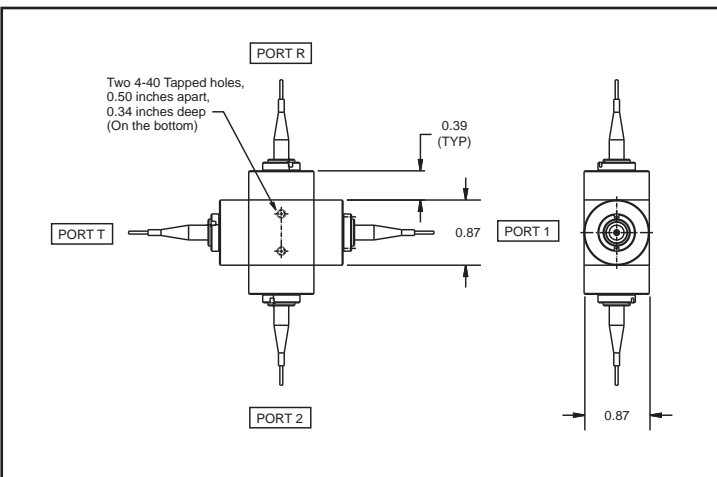

Figure 2: Dimensions of standard two-by-two splitter



Laser Diode Polarization Beam Combiner

## Standard Product Specifications:

In general, OZ Optics uses polarization maintaining fibers based on the PANDA fiber structure when building polarization maintaining components and patchcords. However we can construct devices using other PM fiber structures. We do carry some alternative fiber types in stock, so please contact our sales department for availability. If necessary, we are willing to use customer supplied fibers to build devices.

Parameter	Condition	Value			
Splitting Ratios		50/50, standard			
		Polarizing beam splitter standard			
		Custom split ratios 50/50 to 95/5 available on request			
Splitting Ratio Tolerance:	50/50 splitters	±3%			
	90/10 splitters	±2%			
Central Wavelength:		1550 nm Standard			
		Other wavelengths available on request			
Bandwidth:		±1.5% of the central wavelength			
Wavelength Dependent Loss (WDL):	1520-1570 nm	0.1 dB			
Polarization Extinction Ratios <sup>1</sup> :	630-1600 nm	20 dB minimum, 23 dB typical			
	400-630 nm	17 dB minimum, 20 dB typical			
Polarization Dependent Loss (PDL):		±0.25 dB			
Directivity		>50 dB			
Return Losses <sup>2</sup> :		60 dB <sup>4,6</sup>	50 dB <sup>4,6</sup>	40 dB <sup>5,6</sup>	30 dB <sup>7</sup>
Insertion Losses <sup>2,3</sup> :	Typical	<0.5 dB	<0.9 dB	<0.9 dB	<0.9 dB
	Maximum	<0.6 dB	<1.0 dB	<1.0 dB	<1.0 dB
Power Handling <sup>3</sup>		>1 Watt (+30 dBm)			
Operating Temperature Range:		+0°C to +70°C			
Storage Temperature Range:		-40°C to +85°C			

<sup>1</sup>Higher extinction ratios available for custom orders.

<sup>2</sup>Does not include connector losses and connector return losses.

<sup>3</sup>For 1550 nm wavelengths with either singlemode or polarization maintaining fibers. High power systems can be constructed as required. Contact OZ Optics for other wavelengths or fiber types.

<sup>4</sup>Standard for 1300/1550 nm wavelength bands.

<sup>5</sup>Standard for non-telecom wavelength bands.

<sup>6</sup>Non-telecom products with low return losses and insertion losses available on special order.

<sup>7</sup>Standard for multimode fibers.

## Ordering Information For Standard Parts

The following list is just a subset of available standard parts. In particular, we produce components for a variety of wavelengths. Your choice of connectors can be added to the pigtail style units.

Bar Code	Part Number	Description
11460	FOBS-12P-111-8/125-PPP-1550-50/50-40-XXX-1-1	One-by-two polarization maintaining beam splitter for 1550nm with a 50/50 split ratio, 40dB return loss. All three fibers are one meter long, 900 micron OD loose tube cabled 8/125 polarization maintaining fiber for 1550nm, with no connectors on the fiber ends.
17343	FOBS-12P-111-8/125-PPP-1550-50/50-40-XXX-3-1	One-by-two polarization maintaining beam splitter for 1550nm with a 50/50 split ratio, 40dB return loss. All three fibers are one meter long, 3mm OD Kevlar reinforced PVC cabled 8/125 polarization maintaining fiber for 1550nm, with no connectors on the fiber ends.
9356	FOBS-12P-111-8/125-PPP-1550-50/50-60-XXX-1-1	One-by-two polarization maintaining beam splitter for 1550nm with a 50/50 split ratio, 60dB return loss. All three fibers are one meter long, 900 micron OD loose tube cabled 8/125 polarization maintaining fiber for 1550nm, with no connectors on the fiber ends.
10523	FOBS-12P-111-9/125-SPP-1550-PBS-40-XXX-3-1	One-by-two polarizing beam splitter for 1550nm with 40dB return loss. The input fiber is Corning SMF-28 fiber, while the two output fibers are 8/125 polarization maintaining fibers. All three fibers are one meter long, 3mm OD Kevlar reinforced PVC cabled, with no connectors on the fiber ends.
14862	FOBS-12P-111-9/125-SSS-1550-PBS-40-XXX-3-1	One-by-two polarizing beam splitter for 1550nm with 40dB return loss. All three fibers are one meter long, 3mm OD Kevlar reinforced PVC cabled Corning SMF-28 fiber, with no connectors on the fiber ends.



## Ordering Information For Standard Parts *continued*

Bar Code	Part Number	Description
10620	FOBS-22P-1111-8/125-PPPP-1550-PBS-50-XXXX-1-1	Two-by-two polarizing beam splitter for 1550nm with 50dB return loss. All four fibers are one meter long, 900 micron OD loose tube cabled 8/125 polarization maintaining fiber for 1550nm, with no connectors on the fiber ends.
11922	FOBS-22P-1111-9/125-SSSS-1550-PBS-40-XXXX-1-1	Two-by-two polarizing beam splitter for 1550nm with 40dB return loss. All four fibers are one meter long, 900 micron OD tight jacketed Corning SMF-28 fiber, with no connectors on the fiber ends.
11938	FOBS-22P-1111-9/125-SSPP-1550-PBS-50-XXXX-1-1-ER=25	Two-by-two polarizing beam splitter for 1550nm with 50dB return loss. Both inputs are Corning SMF-28 singlemode fibers, and both outputs are 8/125 polarization maintaining fibers for 1550nm. All four fibers are one meter long, 900 micron OD cabled, with no connectors on the fiber ends. The output polarization extinction ratio is better than 25dB
20677	FOBS-12P-111-6/125-PPP-1053-50/50-40-XXX-1-1	One-by-two polarization maintaining beam splitter for 1053nm with a 50/50 split ratio, 40dB return loss. All three fibers are one meter long, 900 micron OD loose tube cabled 6/125 polarization maintaining fiber for 1053nm, with no connectors on the fiber ends.
21291	FOBS-12P-111-6/125-PPP-1053-PBS-40-XXX-1-1	One-by-two polarizing beam splitter for 1053nm with 40dB return loss. All three fibers are one meter long, 900 micron OD loose tube cabled 6/125 polarization maintaining fiber for 1053nm, with no connectors on the fiber ends.
10869	FOBS-22P-1111-5/125-SSSS-850-PBS-40-XXXX-3-2	Two-by-two polarizing beam splitter for 850nm with 40dB return loss. All four fibers are two meter long, 3mm OD Kevlar reinforced PVC cabled 5/125 singlemode fiber, with no connectors on the fiber ends.

## Ordering Examples For Standard Parts

A research lab is building a fiber interferometer, and requires a polarization maintaining 50/50 splitter for 1550nm. The application requires products with low return losses. No connectors are required, as the customer intends to splice the unit into the system.

Bar Code	Part Number	Description
9356	FOBS-12P-111-8/125-PPP-1550-50/50-60-XXX-1-1	One-by-two polarization maintaining beam splitter for 1550nm with a 50/50 split ratio, 60dB return loss. All three fibers are one meter long, 900 micron OD loose tube cabled 8/125 polarization maintaining fiber for 1550nm, with no connectors on the fiber ends.

## Ordering Information For Custom Parts:

OZ Optics welcomes the opportunity to provide custom designed products to meet your application needs. As with most manufacturers, customized products do take additional effort so please expect some differences in the pricing compared to our standard parts list. In particular, we will need additional time to prepare a comprehensive quotation, and lead times will be longer than normal. In most cases non-recurring engineering (NRE) charges, lot charges, and minimum order will be necessary. These points will be carefully explained in your quotation, so your decision will be as well-informed as possible. We strongly recommend buying our standard products.

## Questionnaire For Custom Parts:

1. What is your operating wavelength?
2. What is the intensity of your signal?
3. What is the first input fiber type?
4. What is the second input fiber type (if needed)?
5. What is the first output fiber type?
6. What is the second output fiber type?
7. What splitting ratio do you desire? Do you require a fixed splitting ratio or a polarizing splitter?
8. Do you intend to use the unit as a splitter or as a combiner?
9. What are your insertion loss requirements?
10. What are your return loss requirements?
11. How long should the fibers be on each port?
12. Do you require uncabled fibers, or fibers protected with a 900 micron diameter loose tube cable?
13. Do you need any connectors on the fibers? If so, what type?

**Description**

**Pigtail Style**  
**One-by-two Splitter**

**Pigtail Style**  
**Two-by-two Splitter**

**Part Number**

**FOBS-12P-111-a/b-ABC-W-S/R-LB-XYZ-JD-L**

**FOBS-22P-1111-a/b-ABC-W-S/R-LB-XYZ-JD-L**

**a/b** = Fiber core/cladding sizes in microns  
 9/125 for 1300/1550 nm singlemode fiber.  
 8/125 for 1550 nm PM fiber  
 7/125 for 1300 nm PM fiber  
 See tables 1 to 5 of the Standard Tables data sheet for other standard fiber sizes

**A,D** = Fiber Types on each port  
**B,C** (Input T, Input R, Output 1 and Output 2)  
 M = Multimode  
 S = Singlemode  
 P = Polarization Maintaining

**W** = Wavelength: Specify in nanometers  
 (Example: 1550 for 1550 nm)

**S/R** = Splitting ratio: 50/50 to 95/5  
 50/50 Standard  
 Use PBS for polarizing splitters

**L** = Fiber length, in meters

**JD** = Fiber jacket type  
 0.25 = 250 micron OD acrylate coating  
 1 = 900 micron OD hytrel jacket  
 3 = 3 mm OD Kevlar reinforced PVC cable

**X,T** = Connector codes for each port

**Y,Z**  
 3S = Super NTT-FC/PC  
 3U = Ultra NTT-FC/PC  
 3A = Angled NTT-FC/PC  
 LC = LC  
 SC = SC  
 SCA = Angled SC  
 See Table 6 of the Standard Tables data sheet for other connectors

**LB** = Backreflection level:  
 30, 40, 50, or 60 dB  
 50, 60 dB are standard for 1300 nm to 1550 nm only  
 40 dB standard for other wavelengths  
 30 dB is standard for multimode

Note: Add "-ER=25" or "-ER=30" to the end of the part number for products with output polarization greater than 25 dB and 30 dB, respectively.

**Description**

**Receptacle Style**  
**One-by-two Splitter**

**Receptacle Style**  
**Two-by-two Splitter**

**Part Number**

**FOBS-12-XYZ-ABC-W-S/R**

**FOBS-22-XYZ-ABC-W-S/R**

**X,T** = Connector codes for each port  
**Y,Z** 3 = FC, Super FC/PC and Ultra FC/PC  
 3AF = Angled Flat NTT-FC  
 SC = SC  
 See Table 6 of the Standard Tables data sheet for other connectors

**A,D** = Fiber Types on each port  
**B,C** (Input T, Input R, Output 1 and Output 2)  
 M = Multimode  
 S = Singlemode  
 P = Polarization Maintaining

**S/R** = Splitting ratio: 50/50 to 95/5  
 50/50 Standard  
 Use PBS for polarizing splitters

**W** = Wavelength: Specify in nanometers  
 (Example: 1550 for 1550 nm)

**Description**

**Pigtail Style Laser Diode to Fiber Splitter**

**Pigtail Style Laser to Fiber Splitter**

**a/b** = Fiber core/cladding sizes in microns  
 9/125 for 1300/1550 nm singlemode fiber.  
 8/125 for 1550 nm PM fiber  
 7/125 for 1300 nm PM fiber  
 See tables 1 to 5 of the Standard Tables data sheet for other standard fiber sizes

**A,B** = Fiber Types on each port  
 (Output 1, Output 2)  
 M = Multimode  
 S = Singlemode  
 P = Polarization Maintaining

**W** = Wavelength: Specify in nanometers  
 (Example: 1550 for 1550 nm)

**S/R** = Splitting ratio: 50/50 to 95/5  
 50/50 Standard  
 Use PBS for polarizing splitters

**f** = Lens ID: See Lens Selection Guide 3 for Non-Contact couplers with receptacles in the Laser to Fiber Coupler Application Notes

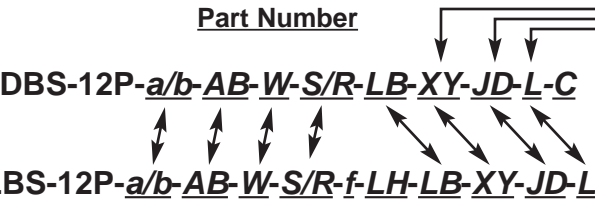

**C** = Coupling Efficiency<sup>1</sup>:  
 30 = 30%  
 45 = 45%  
 75 = 75%

**L** = Fiber length, in meters

**JD** = Fiber jacket type  
 0.25 = 250 micron OD acrylate coating  
 1 = 900 micron OD hytrel jacket  
 3 = 3 mm OD Kevlar reinforced PVC cable

**XY** = Connector codes for each port  
 3S = Super NTT-FC/PC  
 3U = Ultra NTT-FC/PC  
 3A = Angled NTT-FC/PC  
 LC = LC  
 SC = SC  
 SCA = Angled SC  
 See Table 6 of the Standard Tables data sheet for other connectors

**LB** = Backreflection level:  
 30, 40, 50, or 60 dB  
 50, 60 dB are standard for 1300 nm to 1550 nm only  
 40 dB standard for other wavelengths  
 30 dB is standard for multimode

**LH** = Laser Head Adapter  
 1 for 1" -32TPI Male Threaded Adapter  
 2 for Disk Adapter with 4 holes on 1" square  
 11 for Post Mount Adapter  
 See Table 8 of the Standard Tables data sheet for other connectors

<sup>1</sup> Note that due to variations in the optical characteristics of the laser diode being used, not all coupling efficiencies are available for every laser diode for every fiber type.

**Description**

**Receptacle Style Laser Diode to Fiber Splitter**

**Receptacle Style Laser to Fiber Splitter**

**XY** = Connector codes for each port  
 3 = FC, Super FC/PC and Ultra FC/PC  
 3AF = Angled Flat NTT-FC  
 SC = SC  
 See Table 6 of the Standard Tables data sheet for other connectors

**A,B** = Fiber Types on each port  
 (Output 1, Output 2)  
 M = Multimode  
 S = Singlemode  
 P = Polarization Maintaining

**W** = Wavelength: Specify in nanometers  
 (Example: 1550 for 1550 nm)

**S/R** = Splitting ratio: 50/50 to 95/5  
 50/50 Standard  
 Use PBS for polarizing splitters

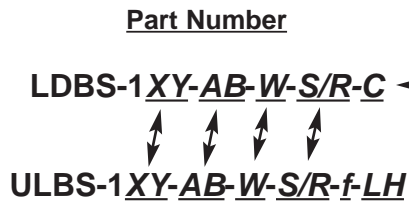

**C** = Coupling Efficiency<sup>1</sup>:  
 30 = 30%  
 45 = 45%  
 75 = 75%

**LH** = Laser Head Adapter  
 1 for 1" -32TPI Male Threaded Adapter  
 2 for Disk Adapter with 4 holes on 1" square  
 11 for Post Mount Adapter  
 See Table 8 of the Standard Tables data sheet for other connectors

**f** = Lens ID: See Lens Selection Guide 3 for Non-Contact couplers with receptacles in the Laser to Fiber Coupler Application Notes

<sup>1</sup> Note that due to variations in the optical characteristics of the laser diode being used, not all coupling efficiencies are available for every laser diode for every fiber type.

## Frequently Asked Questions (FAQs)

Q: Are any epoxies present within the optical path of the device?

A: No epoxies are present between the fiber and the collimation lens, where the intensity of the light is greatest. Some beam splitting optics within the device may consist of cemented prisms, limiting their power handling. However we can provide epoxy-free versions on request.

Q: Can I combine two polarizations into one fiber along the same axis?

A: If you use a 50/50 splitter, you will lose half of each input signal. A polarizing beamsplitter would allow you to combine the beams with low loss, but they would be launched down different polarization axes of a PM fiber. If the output fiber is singlemode, then both polarizations will be scrambled together. If the two sources have different wavelengths, then a polarization maintaining wave division multiplexer (WDM) may be used. OZ Optics offers this device for a variety of common and special wavelength pairs.

Q: How can I combine sources with two different wavelengths into the same fiber, and then split them again into two different fibers?

A: Usually, a device known as a wave division multiplexer is used. This device employs a dichroic filter (it reflects one wavelength and passes another) to combine or separate signals at different wavelengths. This can be done for multimode, singlemode, or PM fibers. Alternatively, if the two signals are carried along PM fiber, then they can be combined using a polarizing beamsplitter. However this idea cannot be used to later separate the two signals.

Q: What advantages do these splitters have over fused splitters (also called biconical taper couplers or taps) or your miniature splitters?

A: Fused splitters are often a good alternative for beamsplitting applications. For singlemode and multimode fiber applications, they offer lower insertion losses, lower return losses, are smaller and are less expensive. Having said that, the polarization maintaining fused splitters currently available on the market have a narrower operating bandwidth and often demonstrate mediocre polarization extinction ratio performance, particularly on the tapped port. The technique used by OZ Optics in our standard beamsplitter design is also inherently more flexible. Different fiber types can be used on each port of the splitter, and the alignment of the polarization transmission axes on each port can be tailored to customer requirements. Systems for unusual wavelengths and unusual fiber types can also be rapidly developed. Finally, specialty high power splitters, capable of transmitting over 10 Watts of optical power can be produced.

As another note, the splitting ratio of multimode fused splitters is dependent on how the light is initially launched into the input fiber. Standard multimode fused splitters rely on the input being a low coherence source, like an LED, to mask this behavior. In contrast, the splitting ratio of the OZ Optics beam splitter is mode independent, thus ensuring correct behavior. If you are still interested in a fused splitter, please check out our Fused Fiber Optic Couplers data sheet for our product offerings.

Q: What is directivity?

A: Directivity is a measure of how much unwanted light can be reflected from one output port on a splitter to the other output port. For example, light from the input port of a 50/50 splitter is normally sent evenly into the two output ports. The directivity is the measure of how much light can be transmitted from one output port to the other output port instead.

Q: I want a polarization combiner and you quoted me a splitter, why?

A: They are the same device used in opposite directions. All splitters are quoted as one fiber to two fibers. As long as your request is clear, your device will work fine.

## Application Notes

**Polarization Extinction Ratio vs Power Extinction Ratio:** For polarizing beamsplitters, the term Extinction Ratio (ER) is often applied to both polarization and power. The power extinction ratio is the ratio between the maximum signal intensity and the minimum signal intensity as the polarization is varied. It is essentially the same as polarization dependent loss, only that we now want this value to be as large as possible instead of as small as possible. In contrast the polarization extinction ratio is a measure of how well the output light from a polarization maintaining fiber is polarized.

Generally speaking the power extinction ratio will always be equal to or greater than the polarization extinction ratio. For example, there can be a splitter with a high power extinction ratio, but if the output PM fibers are not optimally aligned and attached, the output polarization extinction ratio from the fiber would be low. Please be sure to specify both of these values if your system has special requirements. Whenever an ER value is provided for a non-PM fiber system, it refers to the power extinction ratio. The output ratio for each port should also be specified if a lower value is acceptable as this provides for greater manufacturing tolerances and lower pricing.

**Combining Different Fibers:** Fiber optic beam splitters can be designed to couple light from one fiber into an identical fiber or into one with a larger mode field diameter (MFD) and/or numerical aperture (NA). However they cannot be made to transmit light from an input fiber into a fiber with a smaller MFD or NA without high losses. The basic loss estimation is as the square of the mismatch, so if the receiving fiber has a MFD of only  $\frac{1}{2}$  of what is should be, then only  $\frac{1}{4}$  of the light will ideally be coupled. If instead the output fiber is larger, then coupling will be efficient. Therefore, systems cannot be designed to couple light from multimode fiber (for example 50  $\mu\text{m}$  MFD, 0.22 NA) into singlemode or PM fibers (10.5  $\mu\text{m}$  MFD 0.11 NA) with any reasonable efficiency. The most efficient way to circumvent this is to electronically detect the signal and use a second source pigtailed with the desired fiber.

**Using Splitters as Combiners:** A common question we receive is whether a 50/50 beamsplitter can be used in reverse, to combine the signals from two sources, thereby combining their output powers. Unfortunately beamsplitters are reciprocal in nature, meaning that they perform the same operation in both directions. Since the light from the input port on a polarization maintaining splitter will be split 50/50 into the two output ports, light sent back along either one of those ports will also be split 50/50. In a one by two splitter the other 50 percent is simply lost inside the coupler housing. In order to combine signals with low losses the two input signals must somehow be different: for instance light of two different wavelengths or light of two different polarizations can be efficiently combined.

Because of the inherent flexibility of the OZ Optics splitter design, an almost limitless set of configurations are possible. The following set of examples show only a few of the possible applications.

**1. Polarizing splitter / polarization combiner:** A 1x2 splitter is required to split the light from a 1300nm singlemode fiber into two orthogonal polarizations, and then transmit the two signals along two PM fibers. This splitter could also be used in the reverse direction to combine the light from two PM fibers into one singlemode fiber. The two PM fibers are aligned such that for either output port the light is transmitted along the slow axis of the fiber. The output extinction ratios from the PM fibers must be at least 30dB, while the typical backreflection will be 25dB. The singlemode input fiber is terminated with a male FC connector, while the two output fibers are unterminated. All three fibers are cabled using 3mm O.D. kevlar cabling, and are one meter long. OZ Optics' part number: **FOBS-12P-111-9/125-SPP-1300-PBS-25-3XX-3-1-ER-30**

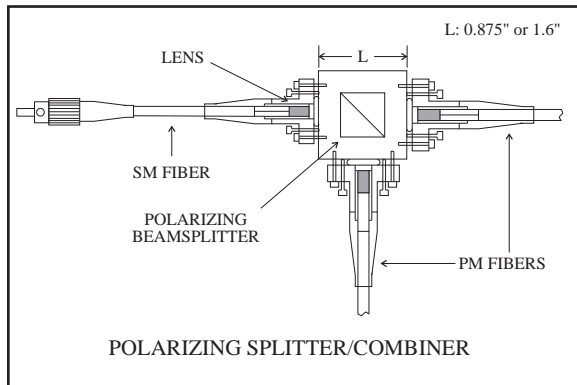

**2. Polarization Analyzer:** The output from a 1300nm singlemode fiber is connected to the input of a connector receptacle style one-by-two splitter. The analyzer consists of a polarizing splitter, an input collimator, and two focusing lenses. The output from each port of the splitter is then connected to a multimode fiber, and the resultant output powers monitored. In this manner one can study the output polarization of light from the fiber. For 1300nm fibers, terminated with ST connectors, the part number for the analyzer with corresponding receptacles is: **FOBS-12-888-SMM-1300-PBS**.

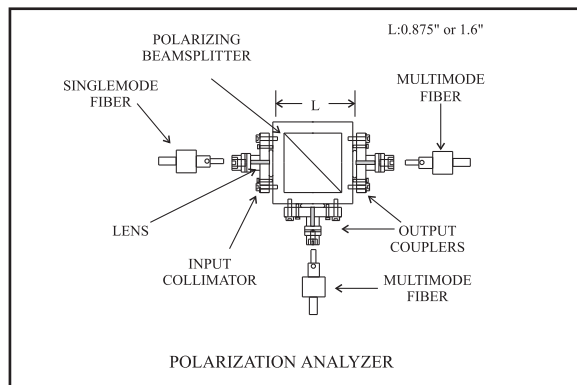

An alternative setup for an analyzer is available with photodiodes attached directly to the output ports rather than using focusing optics and multimode fibers. Such a system can reduce costs and improve coupling efficiency. OZ Optics' part number: **FOBS-12-8XX-SDD-1300-PBS**.

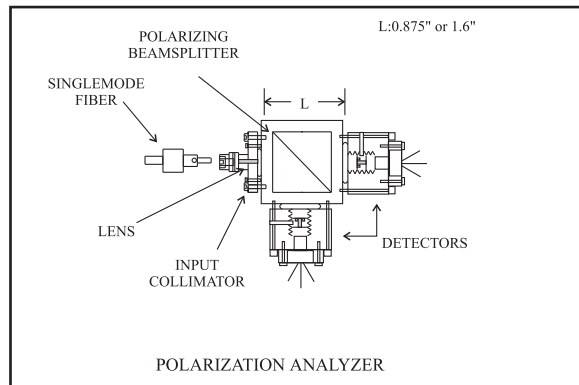

**3. Collimated source to fiber splitter with variable splitting ratio:** A customer wants to couple light from a polarized 488/514nm Ar-Ion laser with 1 - 32 TPI female receptacle into two PM fibers. Both fibers have FC connectors. By using a broadband polarizing splitter to divide the light from the laser, one can rotate the splitter to adjust the splitting ratio between the two fibers to any desired ratio. Achromat lenses are then used to couple the light with equal efficiency for the 488nm and 514nm Ar-Ion laser lines.

OZ Optics part number: **ULBS-133-PP-488/514-PBS-3.5AC-1**. A similar system is available for non-collimated sources, such as laser diodes. For these items a lens is used to initially collimate the source. Add BL to the part # if blocking attenuator is required for each output end.

