



# OZ Optics

shop.ozoptics.com  
www.ozoptics.com

219 Westbrook Road  
Ottawa, ON, Canada, K0A 1L0

Toll free: 1-800-361-5415  
Telephone: 1-613-831-0981  
Fax: 1-613-836-5089  
sales@ozoptics.com

## MODULATOR BIAS CONTROLLER - DITHERLESS

### Features

- Compact
- Ditherless, no. pilot tone
- High dynamic range, high accuracy
- Usable with Mach-Zehnder (MZ) modulator
- Usable for Fabry-Perot fiber control loop-back
- Fast response
- Tunable
- Alarming LED for overtuning

### Product Description

The Ditherless Bias Controller is an OEM version standalone device for bias control in a feedback loop. It locks the bias of the device to the desired reference point. It has many applications, such as for MZ Modulator Bias Control or for Fabry-Perot filter control. Since it does not apply pilot tones, it does not disturb the system, which is very important for many analog systems. It features high accuracy and high dynamic range. The locking slope can be switched with a sliding switch on the board as long as the working function of the device is periodical. When the drift is out of the specified range, the unit will pull the bias back to the desired working point close to 0V. There are two photodiodes built into the board. An external reference voltage can also be applied if specified at the time of order.

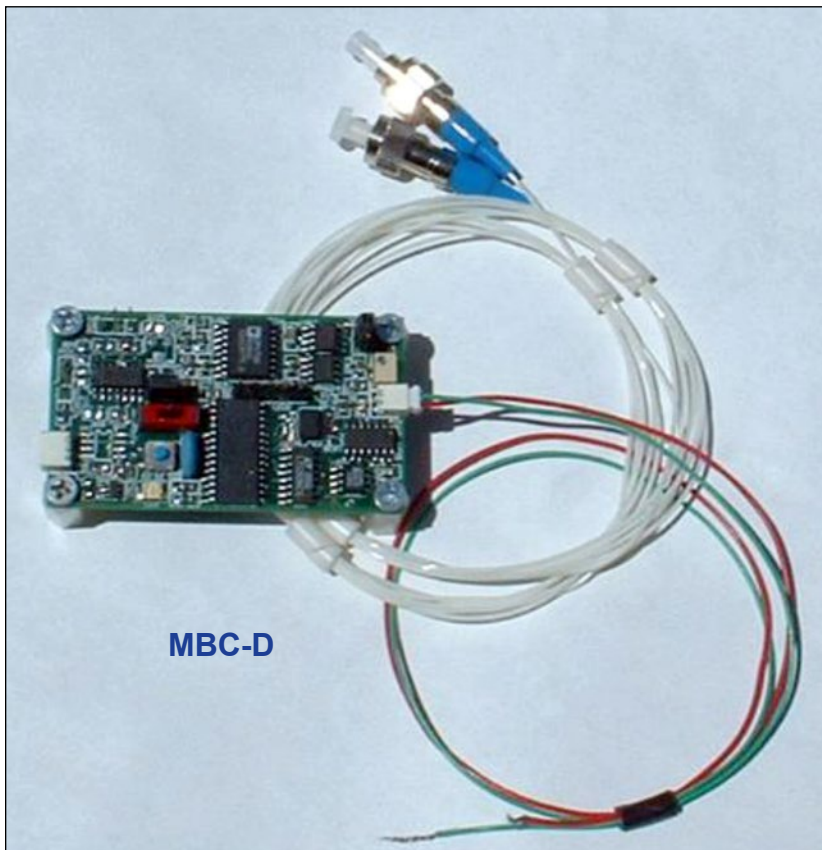

### Specifications

Parameters	Min.	Typ.	Max.
Input Signal Current (mA)	0.1 x 10 <sup>-5</sup>		1
Input Optical Power (dBm)	-50		0
Locking Accuracy (%)		0.1	
DC Bias Voltage (V)	-10		+10
Positive Power Supply (V)	10	12	+15
Negative Power Supply (V)	-10	-12	-15
Positive Supply Current (mA)			35
Negative Supply Current (mA)			20
Operating Temperature (°C)	0-70		
Storage Temperature (°C)	-40-80		
Dimension L x W x H (inch)	2.35 x 1.35 x 0.5		

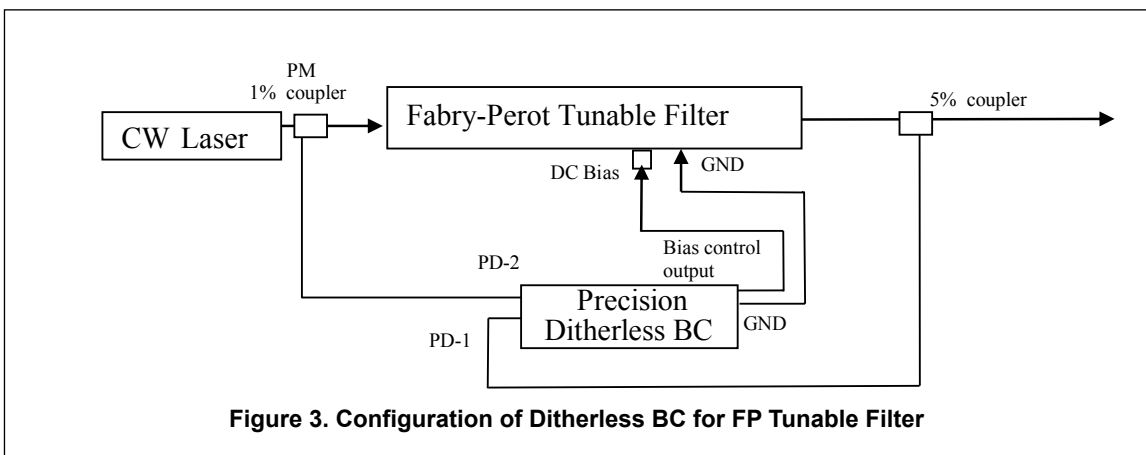
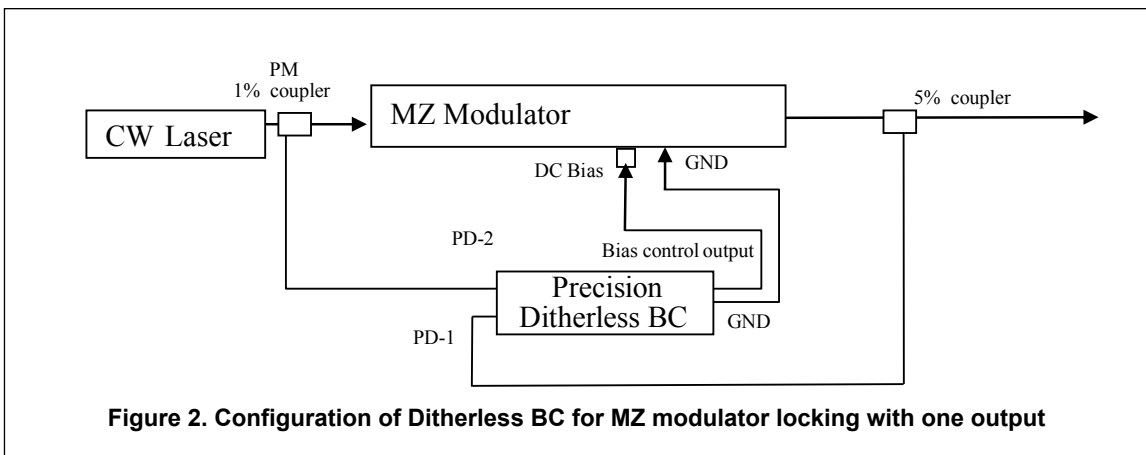
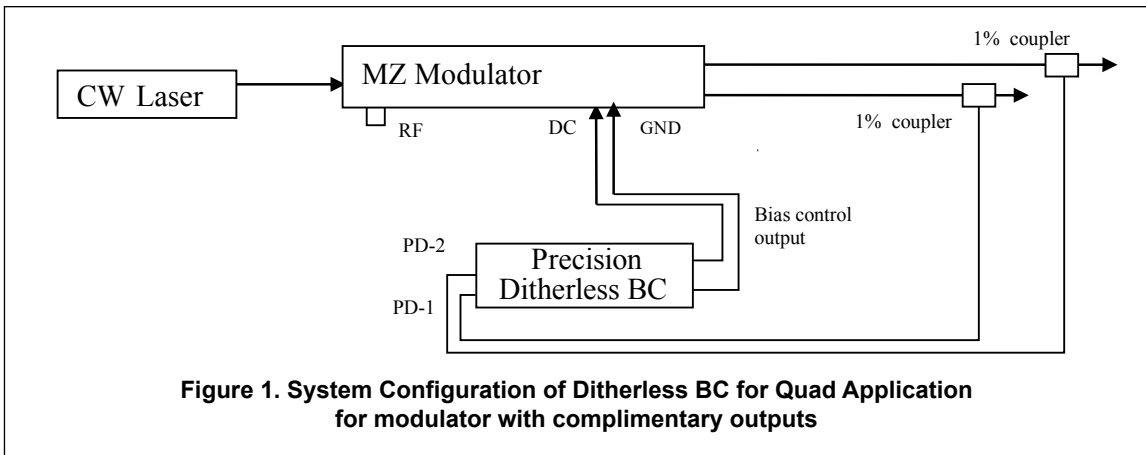

Part Number

***MBC-DBC-X***

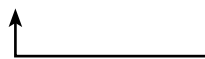

<b>X =</b>	Connector code:
	3U = FC/UPC
	3A = FC/APC
	SCU = SC/UPC
	SCA = SC/APC
	LCU = LC/UPC
	LCA = LC/APC